

---

# A Guardian Roof makes all the difference

  
**Guardian**<sup>™</sup>  
Warm Roof

The ultimate  
solution for  
new or existing  
conservatories

---



# Transform your conservatory into a beautiful garden room

---

The market-leading Guardian Warm Roof is a revolutionary step forward in home improvement – a high performance, lightweight roof replacement system that dramatically transforms your conservatory into an ambient, much needed space that can be used daily, all year round.

*Designed to replace your existing conservatory's glass or polycarbonate roof, the Guardian Warm Roof System retains your original windows, doors frames, walls, and is fully tested and approved to all thermal and structural standards.*





# Engineered for quality

---

With planning consent, internal dividing doors or walls can be removed to provide a permanent extension to give you additional ground floor living space.

## Ridge Cappings

01

Ridge cappings to match roof tiles or slates

## Roof Tiles or Slates

02

Choice of roof tiles or slates in a range of colours

## Gutter System

03

Standard rainwater system

## Membrane

04

Breathable waterproof membrane

## Ply-wood

05

Exterior grade plywood

## Aluminium Frame

06

Structural pre-engineered frame

## Ventilation

07

Ventilated roof eliminates condensation and mould growth

## 3 Layers of Insulation Board

08

High performance rigid insulation board (125mm)





# Building control approval for your peace of mind

---



**Under certain criteria, the Guardian Warm Roof System would be exempt from Building Control approval – however, we strongly recommend that approval always be sought.**

But, as the Guardian Warm Roof System carries LABC / LABSS certification, the Building Control process should proceed faster, smoother and without complication.

Due to the high performance insulation and with Building Control approval, the Guardian Warm Roof System, may allow the removal of the wall between the house and conservatory, providing the flexibility to extend and enlarge an existing kitchen, living room or bedroom.



In compliance with LABC / LABSS, the Guardian Roof is a ventilated roof. Slots in the ring and ridge beams allow air to flow freely through the roof thereby avoiding condensation and allowing any moisture to exit.

*With many unproven roof conversions, moisture can form inside the roof causing staining and mould growth to the internal plasterboard, leading to deterioration or even failure of the roof components.*



## High-performance structural properties

After months of testing the Guardian Roof using various materials, a superior lightweight aluminium frame was chosen due to its high-performance structural properties.

Many roof systems use timber, which weighs significantly more, putting additional stress on the existing conservatory walls. Timber is also prone to shrinkage and is often cut to size on-site unlike the Guardian Roof structural frame which is manufactured and pre-assembled under quality controlled factory conditions.





# Key Features

---

The Guardian™ Warm Roof Conversion System has been designed to provide a high performance thermal and structural solution with zero condensation risk over the life of the roof.



## Energy Efficient

The high performance insulation achieves a superior U-value of only 0.18 W/m.K (England and Wales) and 0.15 W/m.K (Scotland). Saving you money on your heating bills.



## Temperature Control

A Guardian Warm Roof regulates the temperature of your conservatory to ensure that it's pleasant and comfortable all year round.



## Engineered for Quality

Engineered precisely to your individual requirements and pre-assembled under controlled factory conditions to ensure the highest quality.



## Reduced Noise

Your new room will remain quiet and relaxing whatever the weather conditions. Even heavy rain noise is eliminated.





**A living space  
you can enjoy  
whatever the  
weather**

# Roof Design

Guardian provide both standard and bespoke Warm Roof solutions.

**01**

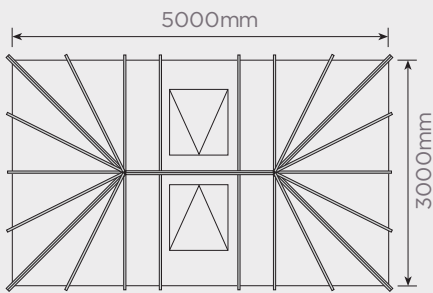

**01**

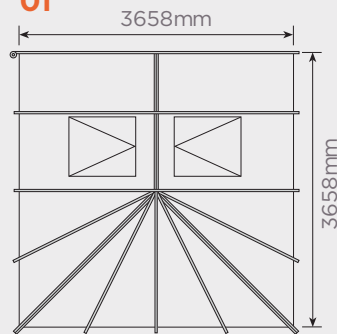

**02**

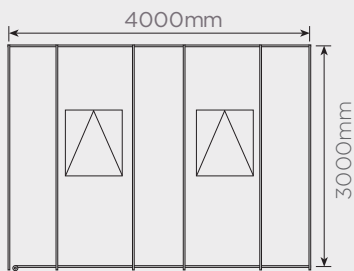

**02**

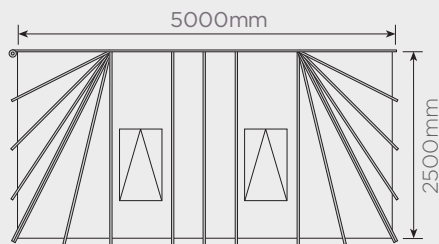

**03**

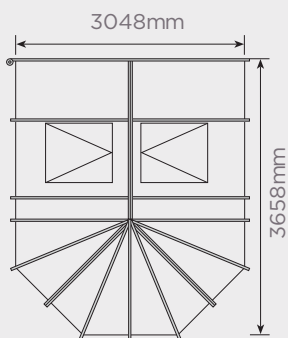

**04**

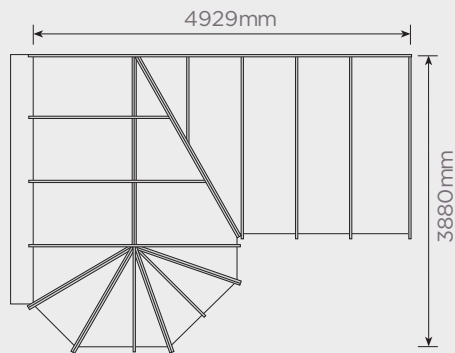

**05**

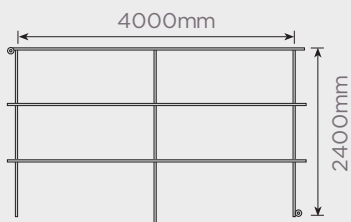



### Edwardian

01

The Classic conservatory shape. Together with attractive roof windows the Edwardian Guardian Roof is the traditional option for styling and convenience, maximising the room space below.



### Lean-to

02

The Guardian Lean-To is ideal to maximise space at the rear of the house. The ends can either have one or two hips (slopes). Ideal for kitchen extensions, the roof can go as low as 15° with roof windows.



### Victorian

03

The Victorian roof is also ideal if you may not have much available space in your garden. The internal plaster finish on the roof has an attractive appearance with its facet front finish.



### Combination

04

A P-shape simply combines the benefits of two different styles to maximise your living environment. A T-shape combination is available, as well as bespoke solutions to make your conservatory as individual as you are.



### Gable Ended

05

The gable ended main feature is the continuous height it brings to the room due to its long central ridge.

The gable end allows you to get the most from your roof windows providing a light and airy space.

*Guardian Warm Roof is suitable to replace your existing roof and also as an alternative on all new conservatory installations.*



# Guardian Slate

---

Today's house builders and owners demand lower cost, faster and easier construction without compromising on quality while maintaining a traditional appearance.

To meet these demands, we are constantly developing new, high tech solutions for today's construction industry. Engineered using the most advanced technology in material development and manufactured from resin bonded crushed limestone, Guardian Slate is extremely durable, impact and heat resistant and offers the highest level of UV protection.

Spacers for perfect alignment

Pre-marked fixing guides for quick & easy installation

Up to 60% lighter than traditional slate

Superior life expectancy will not crack, split or break

Ideal for new or replacement roofing projects

100% recyclable at end of use

'A' grade fire rated on a standard membrane

Consistent high quality and dimensional accuracy



*Guardian Slate is an innovative roofing system featuring the aesthetic appeal of natural slate without the risk of cracking and breaking*



**Available in five natural colours**

Guardian Slate is a lightweight natural slate alternative with no risk of cracking and breaking.

Guardian Slate is available in a choice of five natural colours, providing you the opportunity to add texture and style to your home. The colours have been tested to high UV exposure and exhibit virtually no fade and with no trace of cracking or splitting.

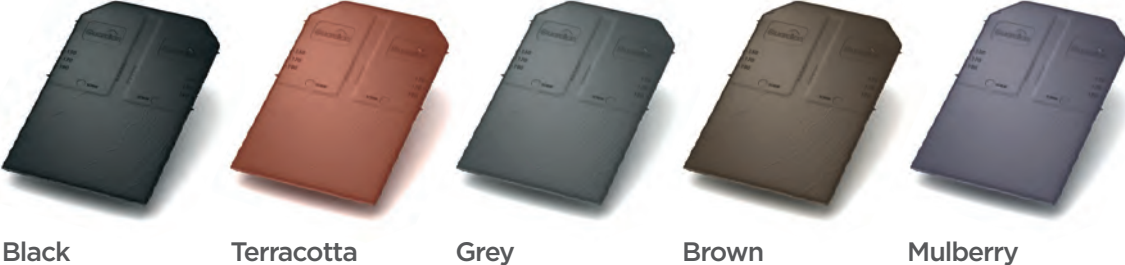



# Guardian Tile

---

The Metrotile is made from lightweight high grade steel with Aluzinc® coating for incredible strength and resistance and features a unique 'hidden fix' feature that leaves no nails exposed to corrosion.

The choice of colours means the tiles can match or compliment virtually any home.



Black



Burnt Umber



Charcoal



Moss Green



Antique Red





# A ideal partner for the Guardian Warm Roof design



# New living space in just a few days

The Guardian Roof System is designed to be of similar weight to a glass roof of equal size, so it follows the existing glazed walls. If correctly specified for the original glazed roof, it should be capable of supporting the replacement Guardian Roof System.



01 The vital first step is to remove the entire existing roof.



02 Timber packer and structural ring-beam are sealed and secured to the top of the window frames.



03 The aluminium rafters, ridges and wall plates are fitted and the spider arms are secured to the spider bracket.



04 Exterior grade ply-board is fixed to the rafters.



05 Breathable waterproof membrane is laid over the ply-wood and secured in place.

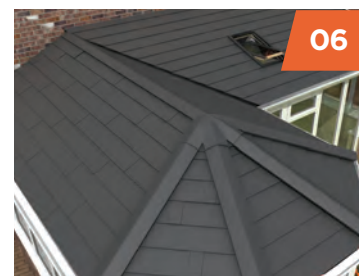

06 Chosen tile is added ensuring weathertightness and the gutter and external trim are secured in place.



07 3 layers of high performance insulation (between and over rafters, and insulated plasterboard), is installed.



08 A total of 125mm insulation is used for outstanding insulating performance.



09 A whole new living space.



# Get it right first time

---

Building work of any kind can be a daunting process. Don't be persuaded to go for an unproven, cheap wrap-over option which will cause you problems and cost you money in the long term.

The Guardian Service Package is the hassle-free way to achieve the roof conversion you want. We will manage your project and keep you informed at every stage, providing a seamless process from your original enquiry, through planning permission to final installation and certification.

*\*LABC / LABSS approval may be necessary. Please consult your Team Guardian Installer.*

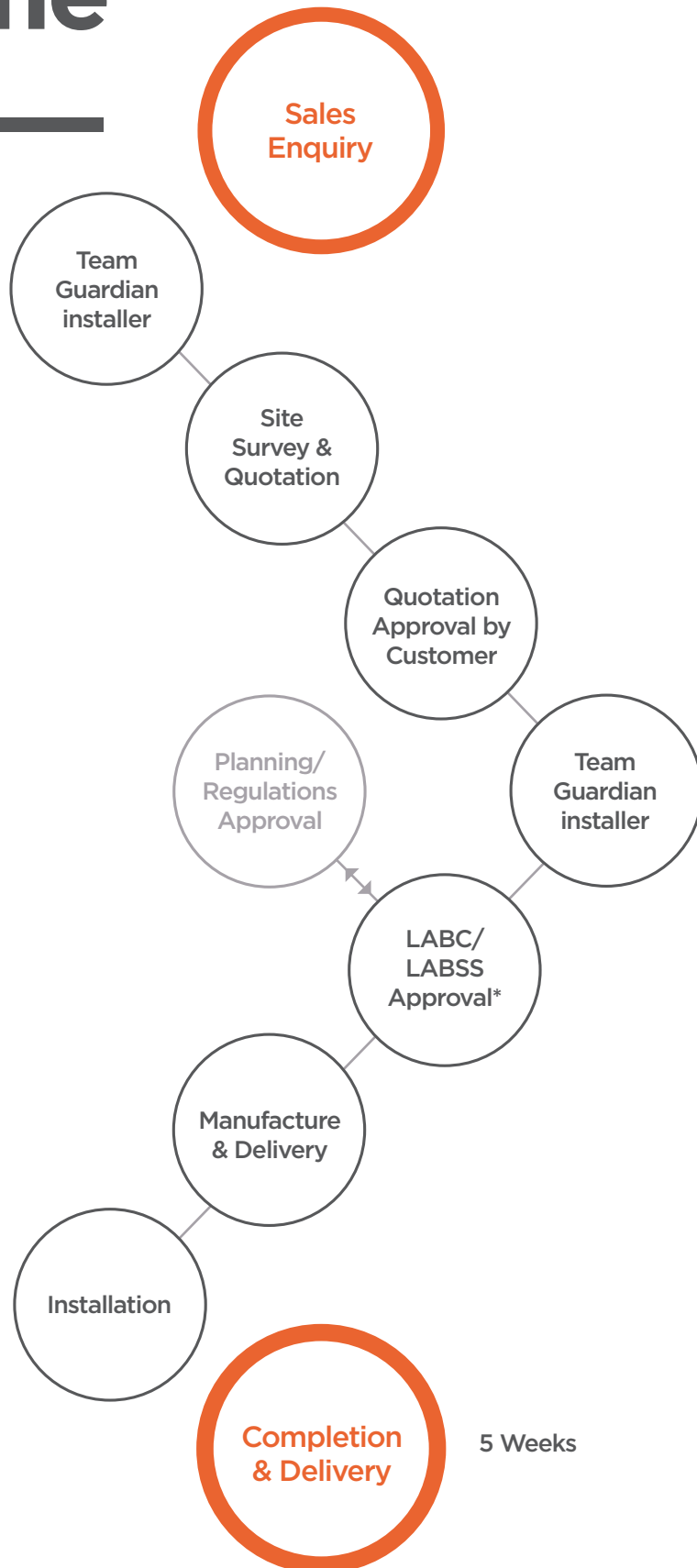



# Make sure it's Team Guardian

---

The Guardian Warm Roof System is manufactured in the UK and It's very important that your new roof is installed professionally. Our installers have been trained, qualified and approved to fit the Guardian Roof System. The installation is the most important process in the whole replacement sequence, so it's really important that your new roof is fitted perfectly.

Simply ask to see our Team Guardian ID and you will be assured that your installer is going to do a great job. The system has been designed to give you additional assurances, not just for the roof itself but also for the quality of the installation.

We are your  
fully approved  
**Team Guardian**  
installers





